

# Appendix - Fork Extension E50 60x150 SP

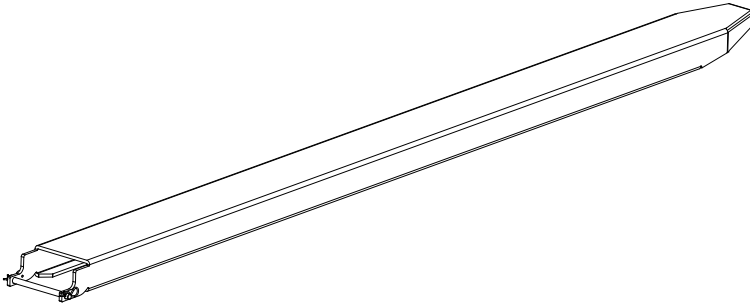

## Description

Special variant of Fork Extension. This Fork Extension has a lower and thinner locking pin at the back and a special profile at the back of the fork.

## Safety\*



### Warning:

Use of the fork extension on forks other than 150x60 mm in cross section (nominal) is forbidden.

\* **NOTE:** This (these) warning(s) is (are) an addition to the safety instructions from the original instruction manual. Please read the safety instructions from the original manual before further use of the Fork Extension.

## Assembly Instructions

1. Pull out the clip (3) on the right and remove the locking pin (1) from the Fork Extension.
2. Place the forks inside the fork Extension.
3. Perform step 1 in reverse order to reassemble and secure the locking pin.

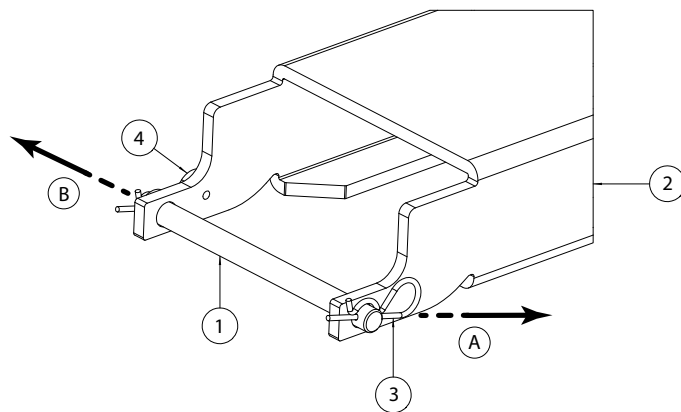

## Spare parts

Pos. N°	Description	Article N°	Quantity:
1	Locking pin	1	1
2	Sleeve	1	1
3	Hairpin cotter 3 mm	39610.030.001	2
4	Hexagon socket cap screw M6x8 DIN 912	07160 M6x8	1

<sup>1</sup> Article N° depending on specific model. Please provide serial number when ordering.

Manual number: MA24082020  
Publication date: 24-08-2020

Language: ENG  
Revision: 01